

REV.	ECN NO.	DATE
00	第一次制定	2009.10.13

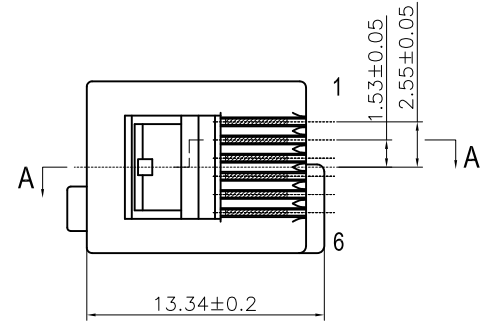

SALT SPRAY	
G/F	8H
3u 6u	24H
15u 30u	48H
50u	

SECTION A-A

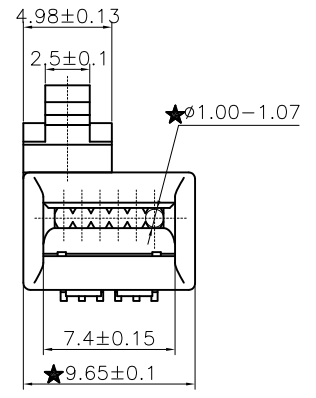
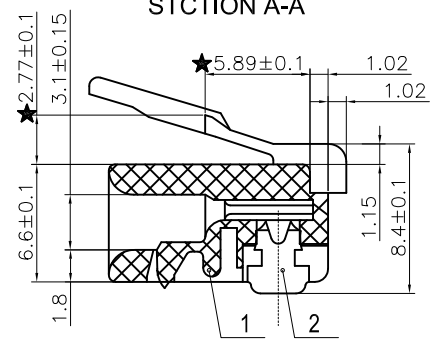

- ELECTRICAL:**
- VOLTAGE RATING: 125 VAC RMS
 - CURRENT RATING: 1.5 AMP
 - CONTACT RESISTANCE: 20mΩ MAX.
 - INSULATION RESISTANCE: 1000MΩ MIN. AT 500V DC.
 - DIELECTRIC STRENGTH: 1000 V AC OR 1500V DC RMS AT 0.5mA 50 Hz / 60 Hz FOR 1 MINUTE
- MECHANICAL:**
- HOUSING MATERIAL: SEE TABLE
 - CONTACT MATERIAL: PHOSPHOR BRONZE/ BRASS T=0.35MM
 - PLATING: GOLD PLATING AT CONTACT AREA, NICKEL 50u" MIN. OVER ALL.
 - MAKE USE OF LING O/D: 0.95±0.05MM
 - OPERATING LIFE: 750 CYCLES MIN.
 - RETENTION STRENGTH: 50N MIN. FOR 60S±5S
- ENVIRONMENTAL:**
- STORAGE: -10°C~+40°C RELATIVE HUMIDITY<80%, GB 10753-89
 - GUARANTEE PERIOD: 12 MONTHS
 - OPERATION: -25°C~+55°C GB 10753-89
 - SALT WATER SPRAY: SEE TABLE

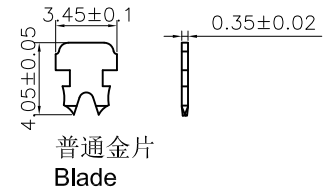
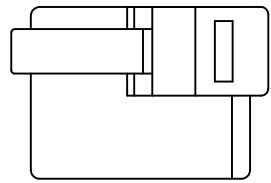
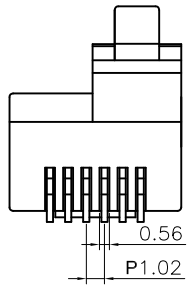

RoHS Compliant

库乐科技

TOLERANCES
公差
00~15 ±0.10
15~30 ±0.15
30~ ±0.20
ANGLES: ±1°

Material: 材质 SEE NOTE
Finish: 电镀 SEE NOTE
SHEET 1 OF 1
第 1 页 共 1 页

Designed: 设计 文夫 2013/09/23
Checked: 审核
Approved: 核准

NAME: 名称 水晶头6P6C左扣位
DWG NO.: 图号 CL3B0110
PART NO.: 料号 SEE NOTE
REV.: 版本 01

第一视角	A4 SIZE	SCALE 比例	UNIT 单位	CUSTOMER: 客户	N/A
		1:1	mm	MODEL NO: 料号	N/A